

63-2030A

THIS DOCUMENT IS CONFIDENTIAL AND CONTAINS PROPRIETARY INFORMATION AND INTELLECTUAL PROPERTY INCLUDING, BUT NOT LIMITED TO, TRADEMARKS, COPYRIGHTS, TRADE SECRETS, AND KNOW-HOW OF ANCHOR GLASS. THIS INFORMATION MAY NOT BE USED, DISCLOSED OR REPRODUCED, IN WHOLE OR IN PART, WITHOUT THE PRIOR WRITTEN CONSENT OF ANCHOR GLASS. TITLE IN AND TO THIS DOCUMENT AND ALL INFORMATION CONTAINED HEREIN REMAINS AT ALL TIMES IN ANCHOR GLASS.

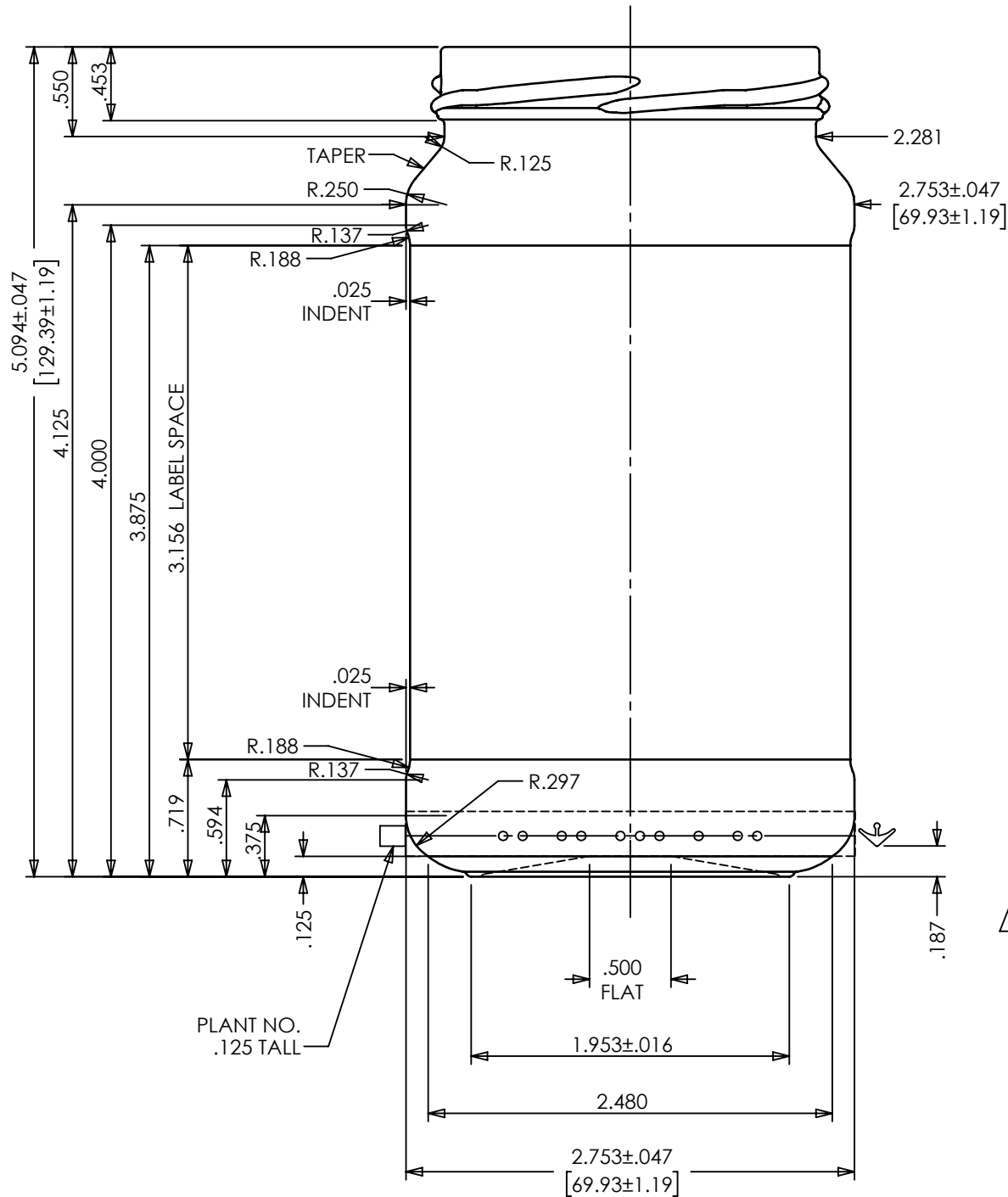

HEEL LETTERING: ROUND NOSED STYLE, RAISED .012"

KNURLING: BPK-160 KNURL TO APPEAR ON BEARING SURFACE

BOTTOM LETTERING: ROUND NOSED STYLE

TRADEMARK: No. 00

STACKING FEATURE: SEE DRAWING C-22539

NOTE:

IF EMHART CAVITY IDENTIFICATION DOT CODE IS USED, THEY WILL APPEAR TWICE, CENTERED ONCE IN EACH HALF AS SHOWN. USE 10 DOT CODE ONLY.

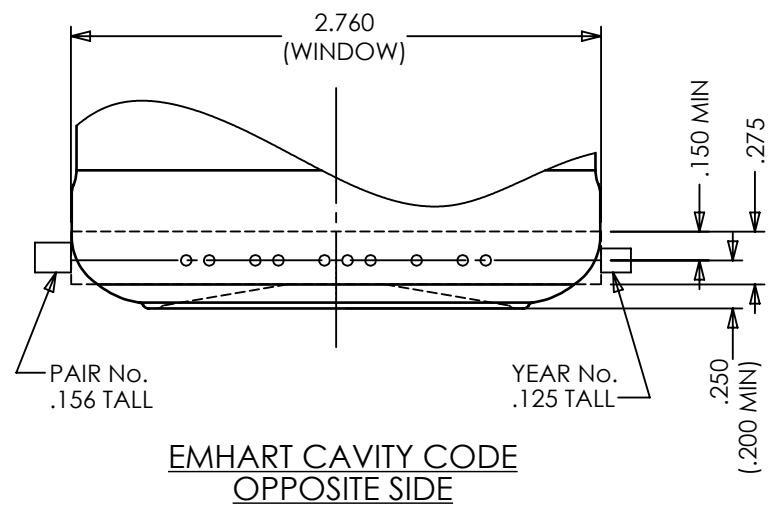

EMHART CAVITY CODE
OPPOSITE SIDE



NOTE:

REGION BETWEEN 1.000 DIA. AND .400 DIA. IS FOR BINARY CAVITY NO. CODE ONLY AND MUST BE FREE OF ALL OTHER LETTERING.

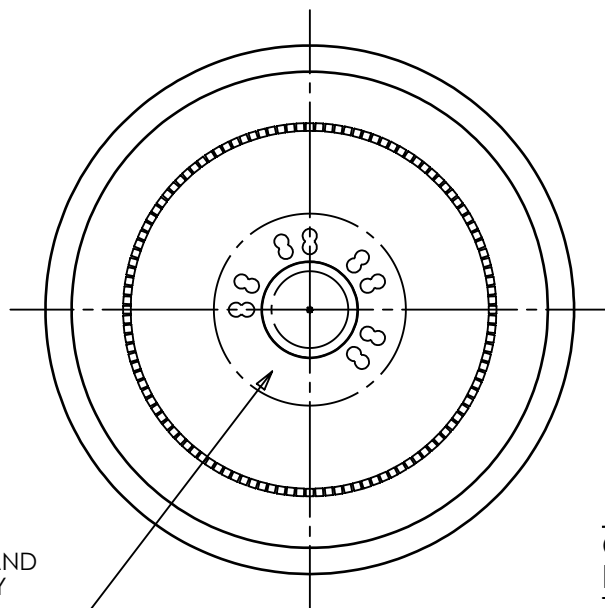

NOTES:

OVERALL HEIGHT: 5.094" (129.39mm)
LARGEST DIAMETER: 2.753" (69.93mm)
THEORETICAL TIP ANGLE > 24° 01'
THEORETICAL C.O.G: 2.191" UP FROM BASE OF BOTTLE

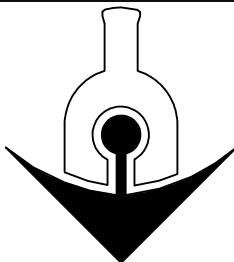

ANCHOR GLASS CONTAINER

DESIGN/ENGINEERING TAMPA, FLORIDA

SIZES & SPECIFICATIONS SHOWN ARE IDEAL ACTUAL SAMPLES WILL DETERMINE SIZES		DESCRIPTION:
SCALE: 1:1	SHAPE CODE: 10	GENERAL SALE
OVERFLOW: 12.710± .218 FL OZS 375.83± 6.447 MLS		375ml JAR
NOMINAL CAPACITY:		ITEM No.: 21337
WEIGHT: 6.875 OZS 194.91 GRAMS		DATE: 10/30/95
PROJECT No: 17473		DRN BY: D. J. Pierce
REFERENCES:		DWG No: C-90756

REV	DESCRIPTION	DATE	APPROVED
5	REDRAWN IN SOLIDWORKS & ADDED DOUBLE CAVITY CODE	1/17/17	S.THOMAS
4	UPDATED TO ANCHOR GLASS STANDARDS	9/26/07	D.TAYLOR
3	WEIGHT WAS 6.380 & OPENED DIAMETERS .022	6/7/02	J.LEE
2	REVISED LABEL AREA	2/5/96	S.
1	ADDED ITEM NUMBER & REMOVED BOTTOM LETTERING	12/13/95	S.
REVISIONS			