

THIS DOCUMENT IS CONFIDENTIAL AND CONTAINS PROPRIETARY INFORMATION AND INTELLECTUAL PROPERTY INCLUDING, BUT NOT LIMITED TO, TRADEMARKS, COPYRIGHTS, TRADE SECRETS, AND KNOW-HOW OF ANCHOR GLASS. THIS INFORMATION MAY NOT BE USED, DISCLOSED OR REPRODUCED, IN WHOLE OR IN PART, WITHOUT THE PRIOR WRITTEN CONSENT OF ANCHOR GLASS. TITLE IN AND TO THIS DOCUMENT AND ALL INFORMATION CONTAINED HEREIN REMAINS AT ALL TIMES IN ANCHOR GLASS.

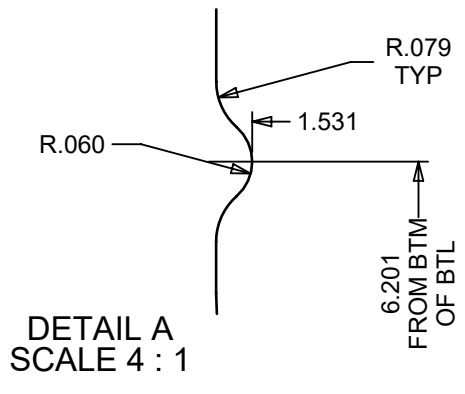

**NOTE:**  
IF EMHART CAVITY IDENTIFICATION DOT CODE IS USED, THEY WILL APPEAR TWICE, CENTERED ONCE IN EACH HALF AS SHOWN. USE 10 TEAR DROP STYLE DOT CODE ONLY.

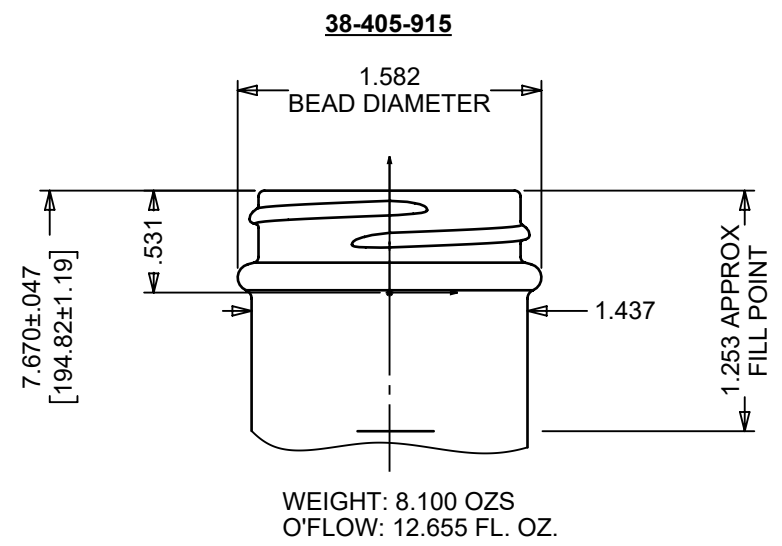
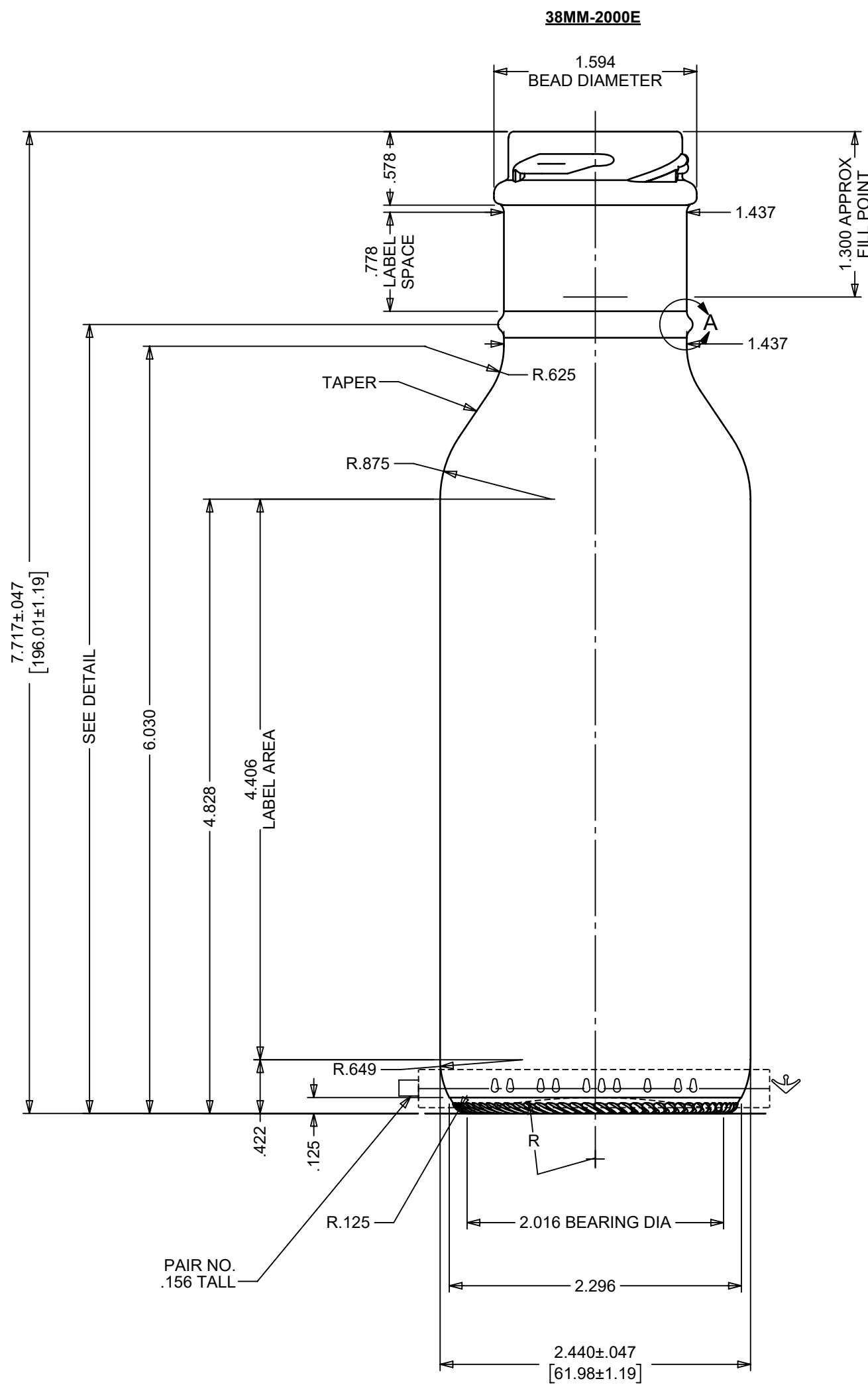
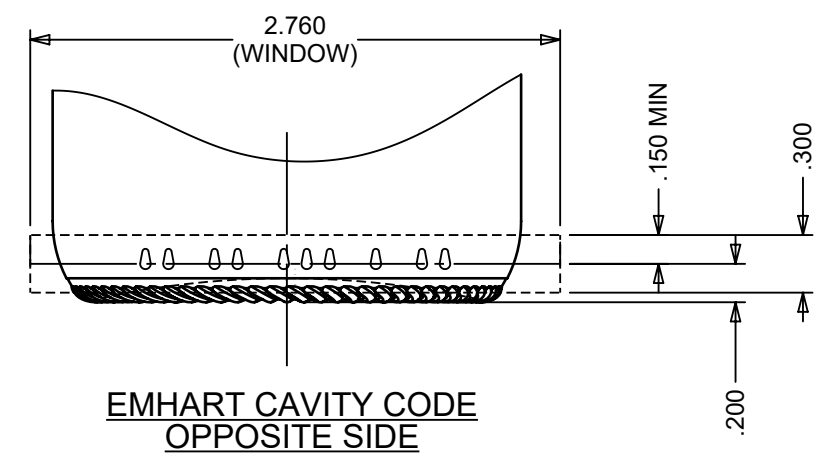

**NOTES:**  
OVERALL HEIGHT: 7.717" (196.01mm)  
LARGEST DIAMETER: 2.440" (69.98mm)  
THEORETICAL TIP ANGLE > 17° 58'  
HEADSPACE: 6.00%  
THEORETICAL C.O.G: 3.889" (98.78mm) UP FROM BASE OF BOTTLE

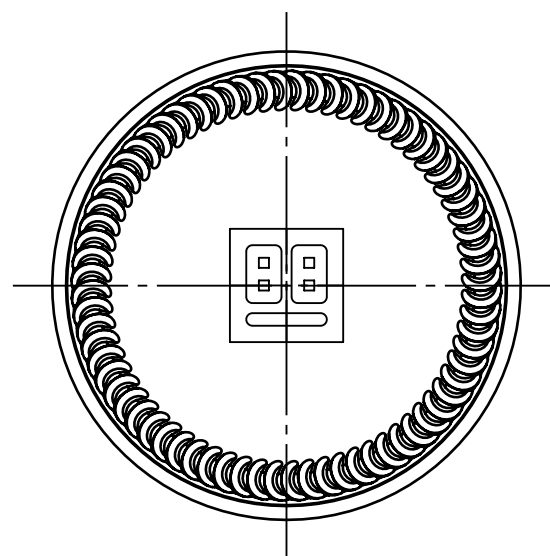

HEEL LETTERING: ROUND NOSE STYLE, RAISED .012"  
KNURLING: CRESCENT KNURLING TO APPEAR ON BEARING SURFACE  
TRADEMARK: No. 00  
BOTTOM PAIR NO. SEE DRAWING BOTT 47-X FOR DETAILS

REV	DESCRIPTION	DATE	APPROVED
2	REMOVED TENTATIVE DESIGN NOTE	3/17/26	JRT
1	ADDED BEAD DIA. ON 38-2000E DRAWING VIEW	1/8/2026	JRT
REVISIONS			

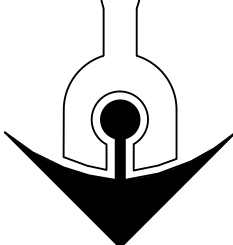

# ANCHOR GLASS

## CONTAINER

TAMPA, FLORIDA

DESIGN/ENGINEERING		DESCRIPTION:	
SIZES & SPECIFICATIONS SHOWN ARE IDEAL ACTUAL SAMPLES WILL DETERMINE SIZES			
SCALE: 1:1	SHAPE CODE: 10	GENERAL SALE	
OVERFLOW: 12.720± .219 FL OZS 376.18± 6.48 MLS		12 FL. OZ. SAUCE / DRESSING	
NOMINAL CAPACITY: 12.000± .219 FL OZS 354.88± 6.48 MLS		ITEM No.: <b>11344</b>	
WEIGHT: 8.100± .375 OZS 229.63± 10.63 GRAMS		DATE: 8/12/25	
PART No.:		DRN BY: S.KING	
PROJECT No: 21702		STATUS:	
REFERENCES:		DWG No: <b>B-98499</b>	
11328A			