

THIS DOCUMENT IS CONFIDENTIAL AND CONTAINS PROPRIETARY INFORMATION AND INTELLECTUAL PROPERTY INCLUDING, BUT NOT LIMITED TO, TRADEMARKS, COPYRIGHTS, TRADE SECRETS, AND KNOW-HOW OF ANCHOR GLASS. THIS INFORMATION MAY NOT BE USED, DISCLOSED OR REPRODUCED, IN WHOLE OR IN PART, WITHOUT THE PRIOR WRITTEN CONSENT OF ANCHOR GLASS. TITLE IN AND TO THIS DOCUMENT AND ALL INFORMATION CONTAINED HEREIN REMAINS AT ALL TIMES IN ANCHOR GLASS.

63-2030J
C-98072

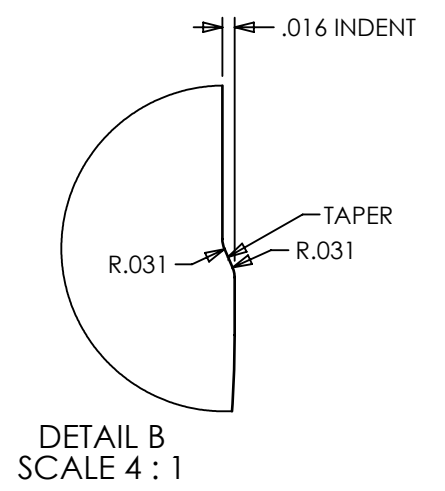

NOTE:
IF EMHART CAVITY IDENTIFICATION DOT CODE IS USED, THEY WILL APPEAR TWICE, CENTERED ONCE IN EACH HALF AS SHOWN. USE 10 TEAR DROP STYLE DOT CODE ONLY.

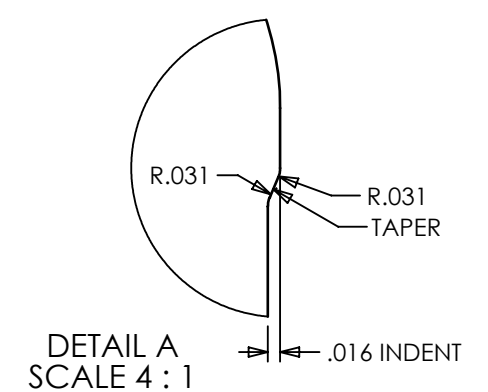
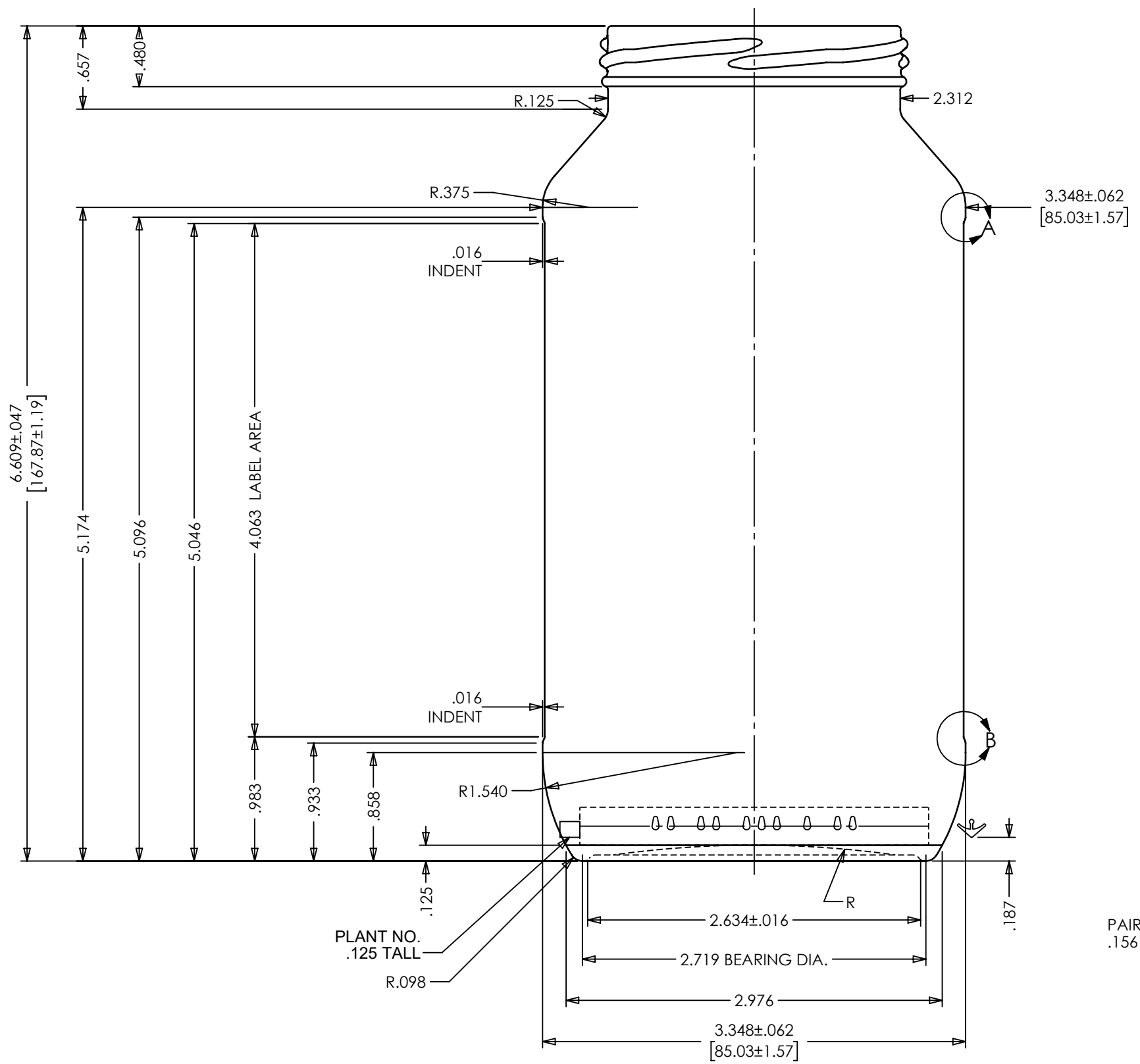
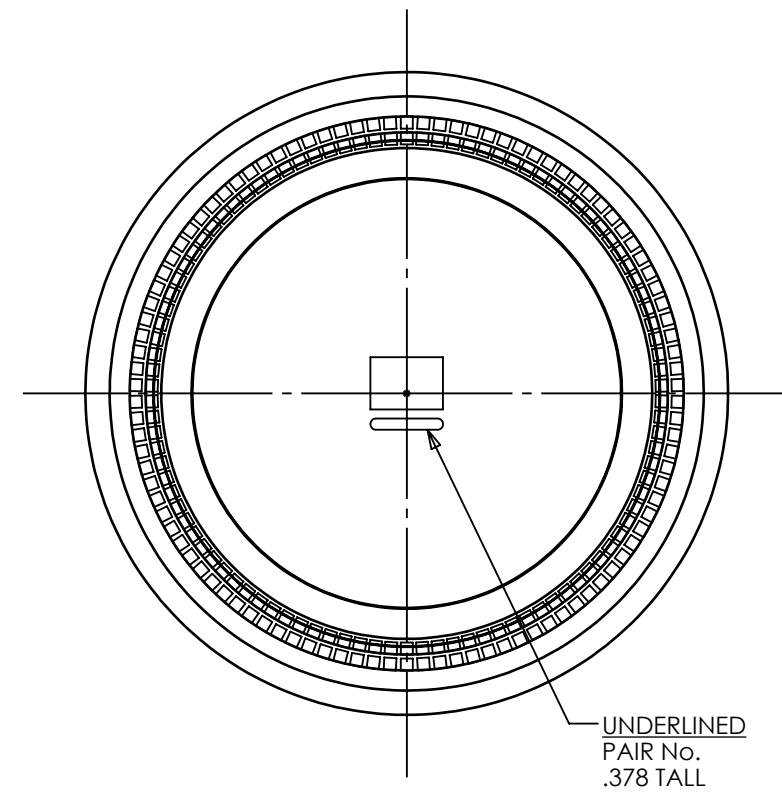
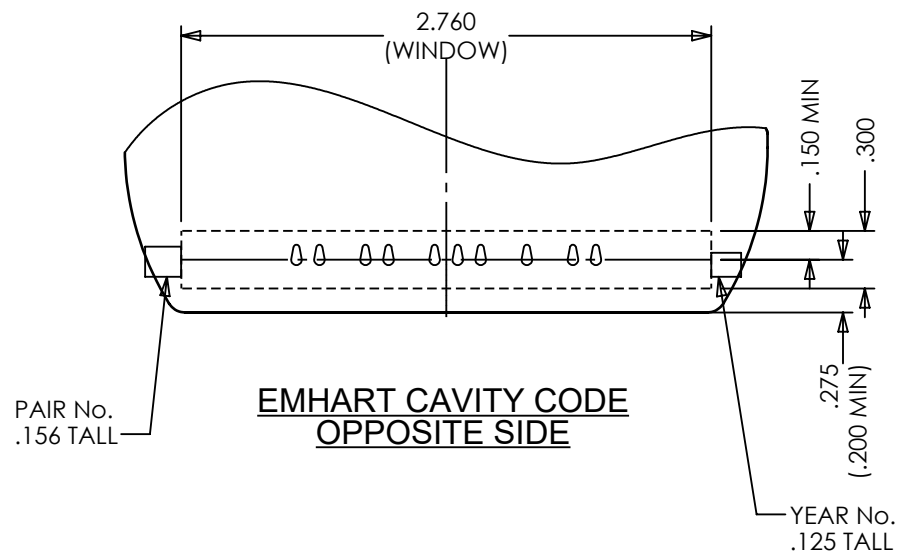

HEEL LETTERING: ROUND NOSE STYLE, RAISED .012"
 KNURLING: BPK-190 KNURL TO APPEAR ON BEARING SURFACE
 BOTTOM PAIR No.: SEE DRAWING BOTT-47 FOR DETAILS WHEN PAIR No. IS USED
 STACKING FEATURE: SEE GPI C-605 FOR DETAILS
 TRADEMARK: No. 00
 ALL NON-TOLERANCE SIZES ARE FOR MOULD MANUFACTURE REFERENCE ONLY

NOTES:
 OVERALL HEIGHT: 6.609" (167.87mm)
 LARGEST DIAMETER: 3.348" (85.03mm)
 THEORETICAL TIP ANGLE > 24° 82'
 THEORETICAL C.O.G: 2.939" UP FROM BASE OF BOTTLE

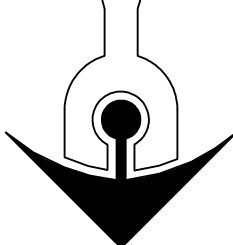

ANCHOR GLASS

CONTAINER

TAMPA, FLORIDA

DESIGN/ENGINEERING		DESCRIPTION:	
SIZES & SPECIFICATIONS SHOWN ARE IDEAL ACTUAL SAMPLES WILL DETERMINE SIZES			
SCALE: 1:1	SHAPE CODE: 12	GENERAL SALE	
OVERFLOW:		24 OZ PASTA SAUCE JAR	
NOMINAL CAPACITY:		ITEM No.:	
24.000± .313 FL OZS 710.00± 9.26 MLS		22460	
WEIGHT:	DATE:	DRN BY:	
12.000± .500 OZS 340.00± 14.17 GRAMS	10/14/2022	D. Myrick	
PART No.:	STATUS:		
-	-		
PROJECT No.:	PB	DWG No.:	
21588	-	B-98306	
REFERENCES: 22455 & TRICOR DWG FOR 710MLPASTA			

REV	DESCRIPTION	DATE	APPROVED
5	CHANGED CUSTOMER NAME TO GENERAL SALE FROM TRICORBRAUN	10/2/25	S.KING
4	REMOVED TENTATIVE DESIGN NOTE, UPDATED PAIR No. NOTE	3/15/23	JRT
3	WEIGHT CHANGED TO 12.000 PER CUSTOMER REQ. & ITEM # ADDED	11/15/22	D.Myrick
2	ADDED TRICOR DWG REFERENCES INTO INFO TITLEBLOCK FIELD	11/08/22	D.Myrick
1	INCREASED WEIGHT .250 OUNCE PER GLASS SAMPLES	10/25/22	DT
REVISIONS			