

THIS DOCUMENT IS CONFIDENTIAL AND CONTAINS PROPRIETARY INFORMATION AND INTELLECTUAL PROPERTY INCLUDING, BUT NOT LIMITED TO, TRADEMARKS, COPYRIGHTS, TRADE SECRETS, AND KNOW-HOW OF ANCHOR GLASS. THIS INFORMATION MAY NOT BE USED, DISCLOSED OR REPRODUCED, IN WHOLE OR IN PART, WITHOUT THE PRIOR WRITTEN CONSENT OF ANCHOR GLASS. TITLE IN AND TO THIS DOCUMENT AND ALL INFORMATION CONTAINED HEREIN REMAINS AT ALL TIMES IN ANCHOR GLASS.

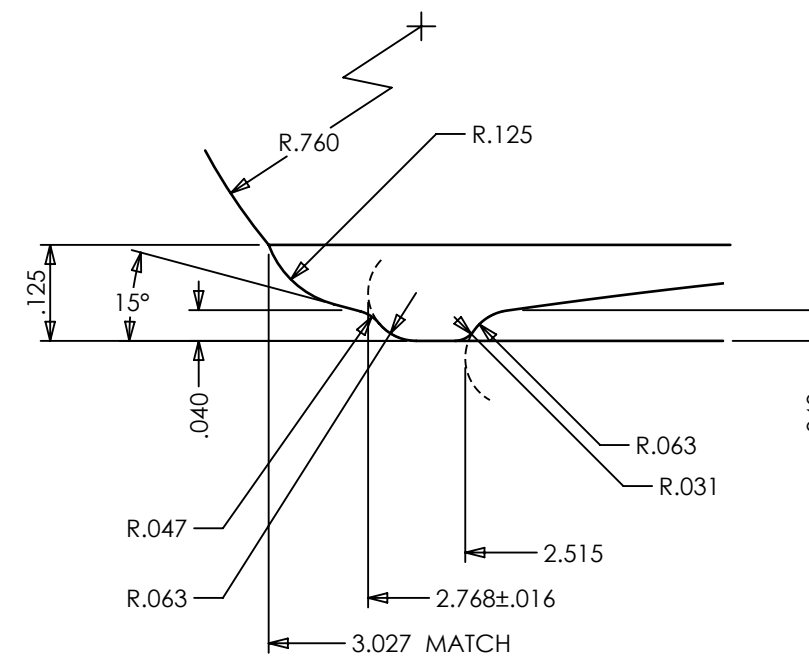

DETAIL A
SCALE 4 : 1

NOTE:
IF EMHART CAVITY IDENTIFICATION DOT CODE IS USED, THEY WILL APPEAR TWICE, CENTERED ONCE IN EACH HALF AS SHOWN. USE 10 DOT CODE ONLY.

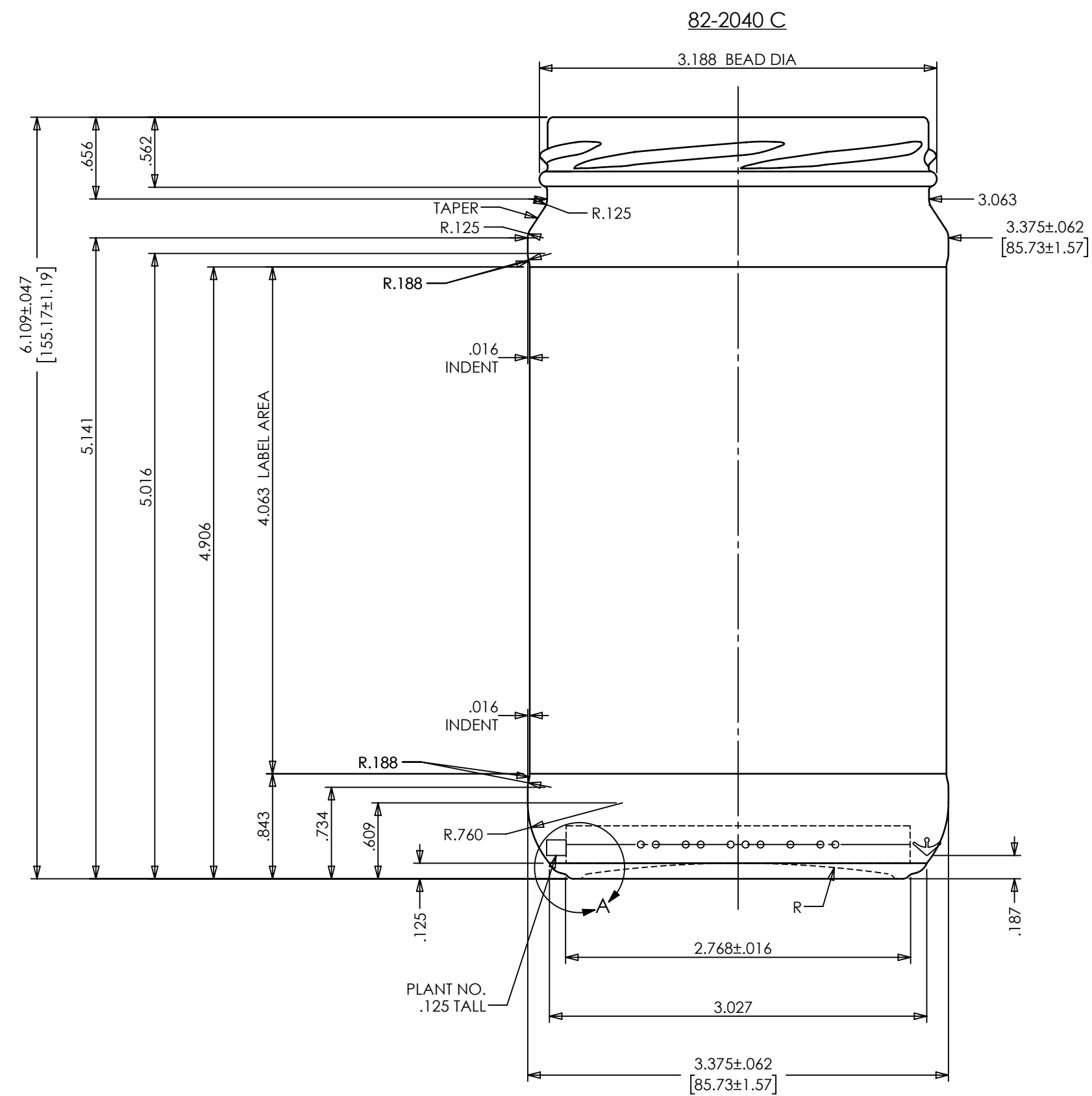
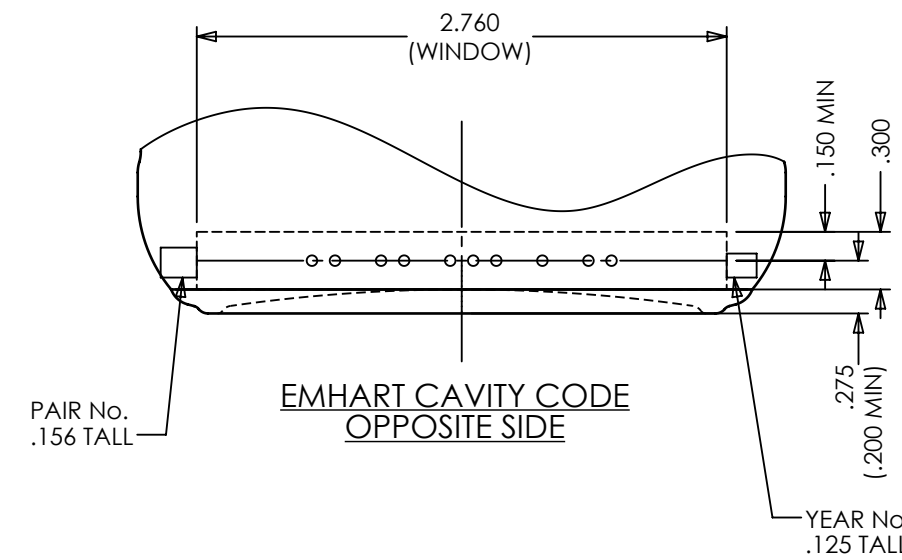

HEEL LETTERING: ROUND NOSE STYLE, RAISED .012"

KNURLING: BPK-180 KNURL TO APPEAR ON BEARING SURFACE

TRADEMARK: No. 00

STACKING FEATURE: AS SHOWN

NOTE: BOTTOM TO BE CLEAR OF ANY MARKINGS

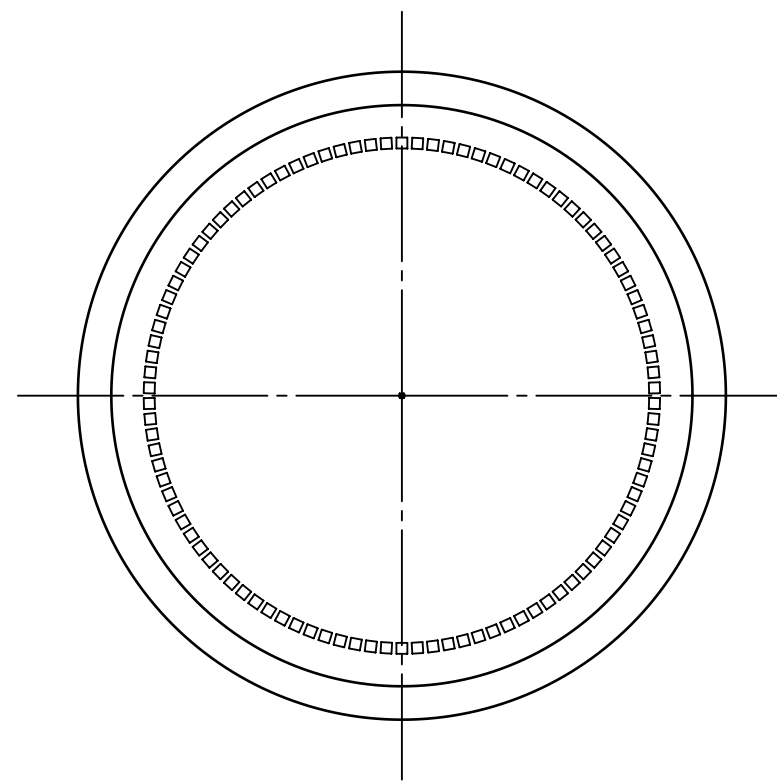

NOTES:
OVERALL HEIGHT: 6.109" (155.17mm)
LARGEST DIAMETER: 3.375" (85.73mm)
THEORETICAL TIP ANGLE > 25° 42'
THEORETICAL C.O.G: 2.735X" UP FROM BASE OF BOTTLE



DESIGN/ENGINEERING		DESCRIPTION:	
SIZES & SPECIFICATIONS SHOWN ARE IDEAL ACTUAL SAMPLES WILL DETERMINE SIZES			
SCALE: 1:1	SHAPE CODE: 10	GENERAL SALE	
OVERFLOW:		24 OZ SALSA	
24.190± .313 FL OZS		ITEM No.:	
715.38± 9.26 MLS		22452	
NOMINAL CAPACITY:		DATE: 7/30/18	
WEIGHT:		DRN BY: S. Thomas	
11.250± .500 OZS		STATUS: APPROVED	
318.93± 14.17 GRAMS		PROJECT No: 21345	
PART No: -		PB DWG No: B-97785	
REFERENCES: T-8287 & 22427			

REV	DESCRIPTION	DATE	APPROVED
5	UPDATED TO GENERAL SALE	4/1/20	S.THOMAS
4	UPDATED CUSTOMER NAME IN TITLE BLOCK	2/27/20	S.THOMAS
3	REMOVED TENTATIVE NOTE AND BOTTOM PAIR No.. ADDED BOTTOM TO BE CLEAR NOTE	12/13/18	S.THOMAS
2	CORRECTED CAPACITY TOLERANCE, WAS .188 FL OZS	9/24/18	S.THOMAS
1	UPDATED STACKER FEATURE DESIGN & ADDED ITEM No.	9/19/18	S.THOMAS
REVISIONS			