

THIS BOTTLE IS DESIGNED TO PROVIDE CROWN REST CLEARANCE INDICATED ONLY. CUSTOMER MUST ADVISE IF ANY SPECIAL CLEARANCES ARE REQUIRED.

IT IS THE RESPONSIBILITY OF THE GLASS CONTAINER PURCHASER TO CONSULT WITH IT'S CLOSURE AND CONTAINER SUPPLIERS TO DETERMINE THE APPROPRIATE PRESSURE LIMITS FOR THE COMBINATION OF THE CONTAINER, IT'S FINISH, AND THE CLOSURE CHOSEN, WHEN THE CONTAINER WILL BE SUBJECTED TO PRESSURE OR UTILIZED FOR CONTENTS UNDER PRESSURE.

THIS CONTAINER IS DESIGNED FOR PRODUCTS UP TO AND INCLUDING 4 GAS VOLUMES WITH NO PASTEURIZATION.

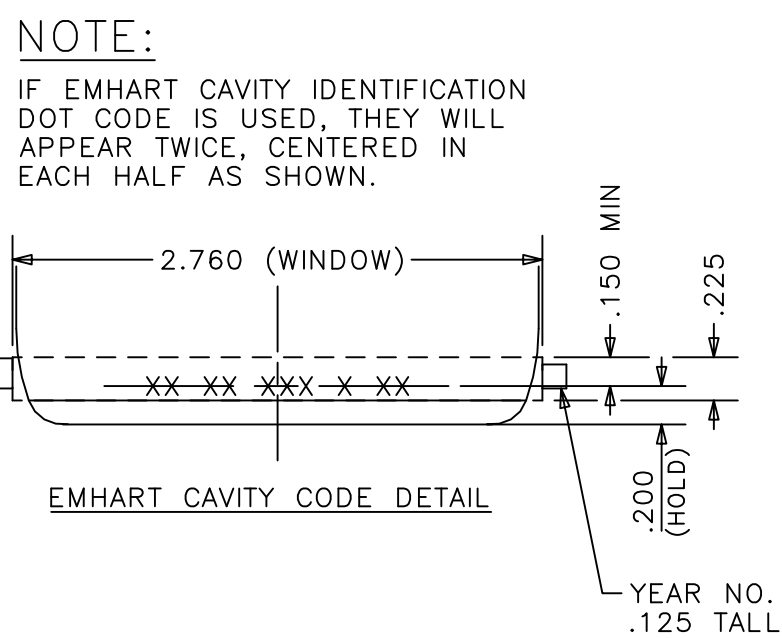

HEEL LETTERING: ROUND NOSED, RAISED .012 MAX.
 KNURLING: CRESCENT ON BEARING SURFACE.
 BOTTOM LETTERING: ROUND NOSED.
 TRADEMARK: NO. 00.

THIS DOCUMENT IS CONFIDENTIAL AND CONTAINS PROPRIETARY INFORMATION AND INTELLECTUAL PROPERTY INCLUDING, BUT NOT LIMITED TO, TRADEMARKS, COPYRIGHTS, TRADE SECRETS, AND KNOW-HOW OF ANCHOR GLASS. THIS INFORMATION MAY NOT BE USED, DISCLOSED OR REPRODUCED, IN WHOLE OR IN PART, WITHOUT THE PRIOR WRITTEN CONSENT OF ANCHOR GLASS. TITLE IN AND TO THIS DOCUMENT AND ALL INFORMATION CONTAINED HEREIN REMAINS AT ALL TIMES IN ANCHOR GLASS.

NOTE!
 OVERALL HEIGHT ----- 9.649"(245.08mm)
 LARGEST DIAMETER ----- 2.721"(69.11mm)

NOTE: THEORETICAL TIP ANGLE > 17° 23'. HEADSPACE = 5%
 THEORETICAL C.O.G. = 3.572" UP FROM BTM OF BTL.

NOTE:
 REGION BETWEEN 1.000 DIA. & .400 DIA. IS FOR BINARY CAVITY CODE No. ONLY, AND MUST BE FREE OF ALL OTHER LETTERING.

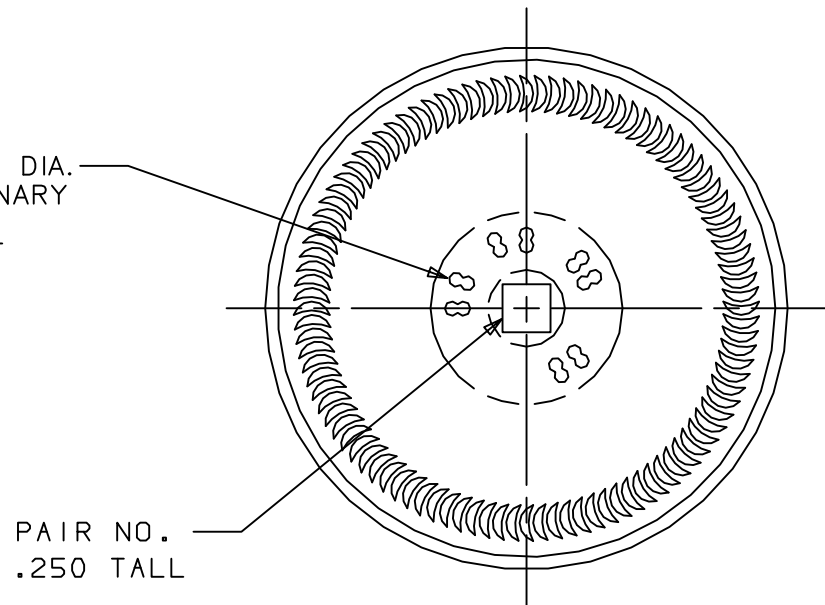

REVISIONS	
9. ADDED 28-1650 FINISH	6/29/18 DT
8. REMOVED SPOT RAMP PER APPROVAL DWG B-97464 - ADDED "A" TO ITEM NUMBER	3/17/17 SODE
7. ADDED 26-6611 FINISH	9/23/14 DT
6. UPDATED ANCHOR LOGO	8/4/14 SODE
5. REMOVED "TENTATIVE" NOTE	08/04/08 SODE
4. REVERTED BACK TO REV #2, REMOVED DECO AND ADDED SPOT RAMP BACK	4/7/08 SODE
3. MODIFY SHOULDER CONSTRUCTION AND BODY DIAMETERS FOR DECORATION - INCREASED WEIGHT FOR CAPACITY - REMOVE SPOTTING RAMP.	2-4-08 DT
2. ADDED ITEM NUMBER	1/24/08 SODE
1. INCREASED HEEL STRAIGHT - ADD SPOTTING RAMP PER CUSTOMER.	1-21-08 DT

SIZES & SPECIFICATIONS SHOWN ARE IDEAL - ACTUAL SAMPLES WILL DETERMINE SIZES.	
SCALE: FULL	SHAPE CODE: 10
OVERFLOW:	
16.800 ±.281 FL OZS	
496.82 ±8.31 MLS	
FILL POINT OR NOMINAL CAPACITY:	
16.000 ±.281 FL OZS	
473.16 ±8.31 MLS	
WEIGHT:	10.875 OZS
	308.33 GRAMS
PROJECT No.	20158 BB
REF:	81612A

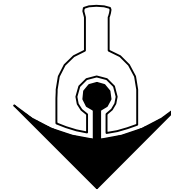

ANCHOR GLASS CONTAINER

DESIGN/ENGINEERING TAMPA, FLORIDA

GENERAL SALE	
16.000 FL OZ N/R BEVERAGE	
ITEM No. 61694A	
DATE 01/08/08	DRN. BY J. Sode
DWG. No.: B-95405	