

38-2000 C  
C-93075

THIS DOCUMENT IS CONFIDENTIAL AND CONTAINS PROPRIETARY INFORMATION AND INTELLECTUAL PROPERTY INCLUDING, BUT NOT LIMITED TO, TRADEMARKS, COPYRIGHTS, TRADE SECRETS, AND KNOW-HOW OF ANCHOR GLASS. THIS INFORMATION MAY NOT BE USED, DISCLOSED OR REPRODUCED, IN WHOLE OR IN PART, WITHOUT THE PRIOR WRITTEN CONSENT OF ANCHOR GLASS. TITLE IN AND TO THIS DOCUMENT AND ALL INFORMATION CONTAINED HEREIN REMAINS AT ALL TIMES IN ANCHOR GLASS.

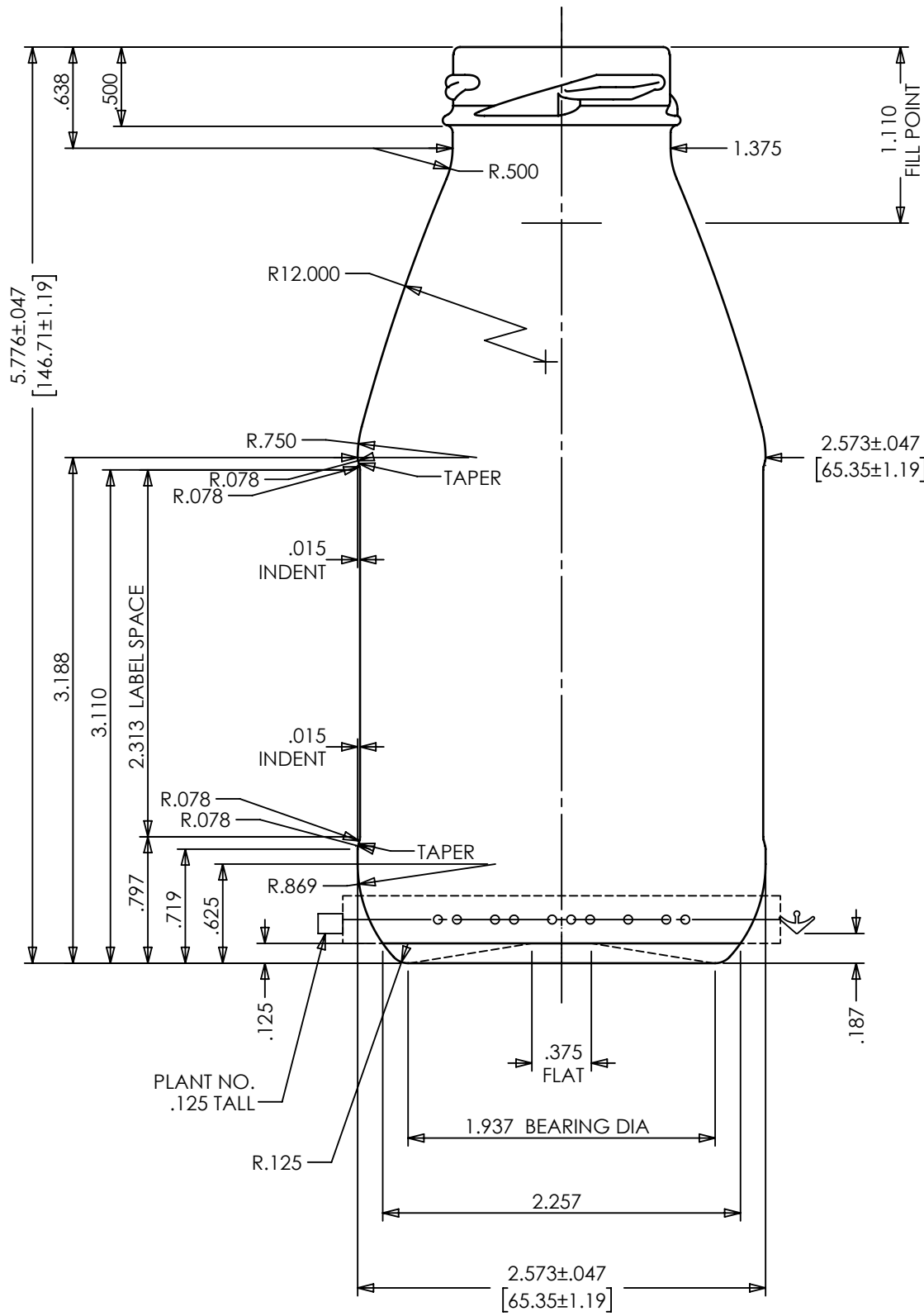

HEEL LETTERING: ROUND NOSED STYLE, RAISED .012"

KNURLING: CRESCENT KNURL TO APPEAR ON BEARING SURFACE

BOTTOM LETTERING: ROUND NOSED STYLE

NOTE:  
IF EMHART CAVITY IDENTIFICATION DOT CODE IS USED, THEY WILL APPEAR TWICE, CENTERED ONCE IN EACH HALF AS SHOWN. USE 10 DOT CODE ONLY.

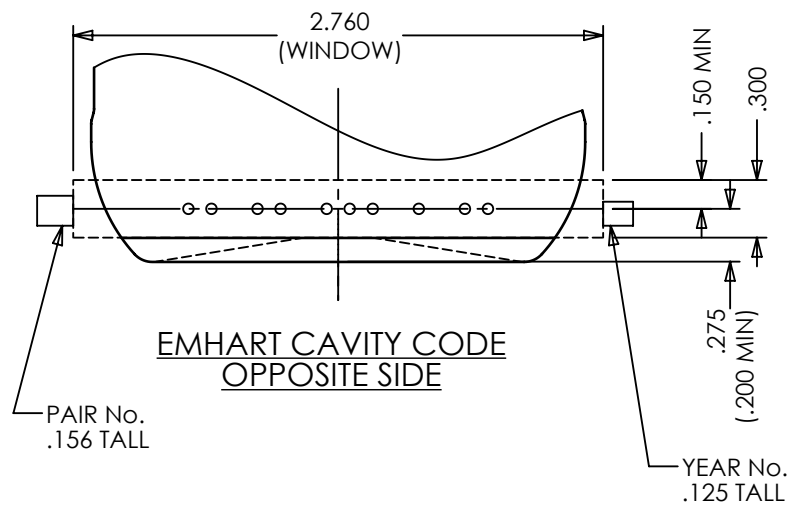

NOTE:  
REGION BETWEEN 1.000 DIA. AND .400 DIA. IS FOR BINARY CAVITY NO. CODE ONLY AND MUST BE FREE OF ALL OTHER LETTERING.

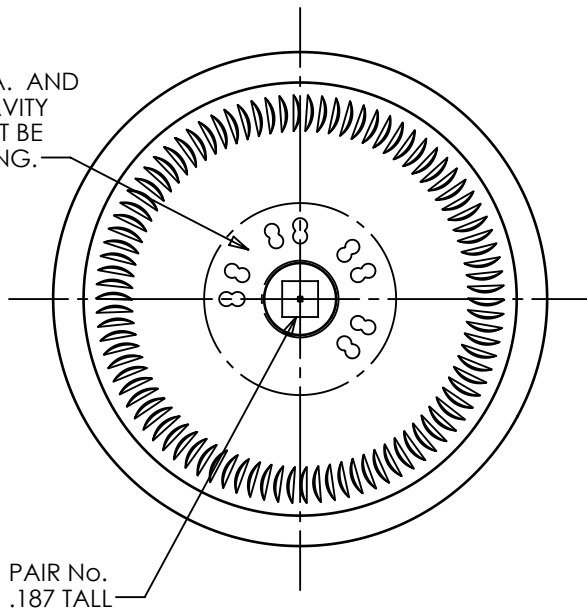

NOTES:  
OVERALL HEIGHT: 5.776" (146.71mm)  
LARGEST DIAMETER: 2.573" (65.35mm)  
THEORETICAL TIP ANGLE > 22° 31'  
HEADSPACE: 5.7%  
THEORETICAL C.O.G: 2.337" UP FROM BASE OF BOTTLE

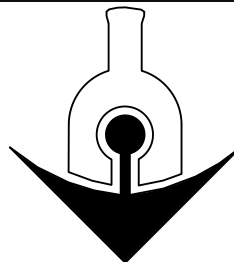

# ANCHOR GLASS CONTAINER

DESIGN/ENGINEERING		TAMPA, FLORIDA	
SIZES & SPECIFICATIONS SHOWN ARE IDEAL ACTUAL SAMPLES WILL DETERMINE SIZES		DESCRIPTION:	
SCALE: 1:1	SHAPE CODE: 10	GENERAL SALE	
OVERFLOW: 10.720± .187 FL OZS 317.00± 5.53 MLS		300ml JUICE BOTTLE	
NOMINAL CAPACITY: 10.145± .187 FL OZS 300.00± 5.53 MLS		ITEM No.: 11107	
WEIGHT: 5.500 OZS 155.93 GRAMS		DATE: 9/6/00	
PROJECT No: 14473		DRN BY: C.N. MACHADO	
REFERENCES:		DWG No: C-85812	

REV	DESCRIPTION	DATE	APPROVED
16	REDRAWN IN SOLIDWORKS & CHANGED HEEL LETTERING	9/8/16	S.THOMAS
15	UPDATED LOGO	8/4/14	SODE
14	UPDATED TO LATEST ANCHOR GLASS STANDARDS	8/17/07	DT
13	CORRECTED FINISH TO 38-2000C & UPDATED DWG	9/6/00	CNM
12	REMOVED 38-1650 FINISH	1/22/98	SODE
REVISIONS			