

NOTE :
 IF EMHART CAVITY IDENTIFICATION DOT CODE IS USED, THEY WILL APPEAR TWICE, CENTERED ONCE IN EACH HALF AS SHOWN.
 DOT'S NOT TO BE IN CONTACT

NOTE !
 OVERALL HEIGHT ----- 7.213" (183.21mm)
 LARGEST DIAMETER ----- 2.828" (71.83mm)

NOTE: THEORETICAL TIP ANGLE > 19° 48'.
 THEORETICAL C.O.G. = 2.976" UP FROM BTM OF BTL.

NOTE :

REGION BETWEEN 1.000 DIA. & .400 DIA. IS FOR BINARY CAVITY CODE No. ONLY, AND MUST BE FREE OF ALL OTHER LETTERING.

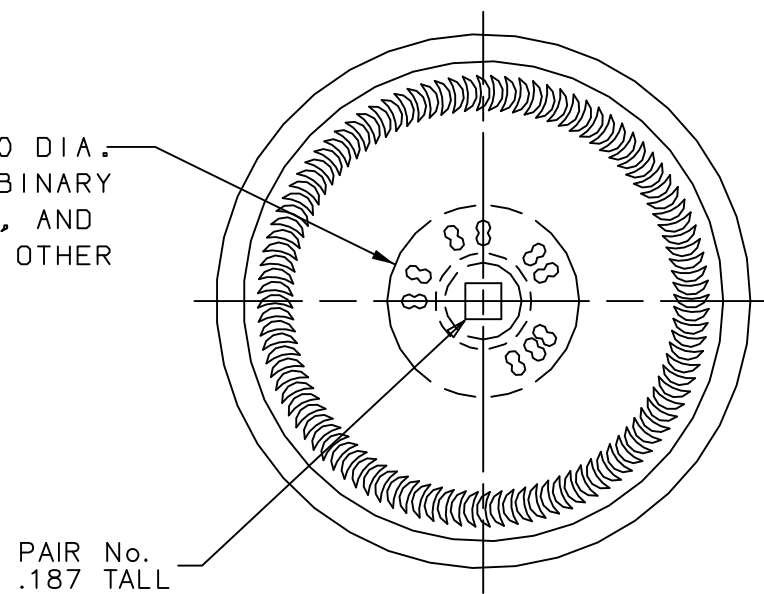

HEEL LETTERING: ROUND NOSED STYLE.
TRADEMARK: No. 00
SHOULDER DECO: (10) EQUALLY SPACED FLUTES TO APPEAR AROUND SHOULDER AS SHOWN. FLUTES TO BE .020 DEEP AND GRADUALLY FADING OUT AT NECK END.
KNURLING: CRESCENT TO APPEAR ON BEARING

- 4. O.A.H. WAS 7.177 WITH 28-1768A FINISH, REV TO MATCH MOULD EQUIP 10/19/12 SODE
- 3. REMOVED APC 33X16 FINISH, ADJUSTED O'FLOW CAPACITY, WAS 16.810 FL OZ 10/13/06 SODE
- 2. REDRAWN AND UPDATED PER A.G.C.C. STD'S. WAS GLENSHAW ITEM NO. 3518. REMOVED 28-405 05/17/04 P. STEH
- 1. REDRAWN WITH ACP 33 X 16 "J" CAP FINISHES PER SALES. 05/02/97

REVISIONS

SIZES & SPECIFICATIONS SHOWN ARE IDEAL -ACTUAL SAMPLES WILL DETERMINE SIZES.			ANCHOR GLASS CONTAINER	
SCALE: FULL	SHAPE CODE: 12		DESIGN/ENGINEERING TAMPA, FLORIDA	
OVERFLOW: 16.706 ± .250 FL. OZ. 494.04 ± 7.39 ML.		GENERAL SALE		
FILL POINT OR NOMINAL CAPACITY:		16 FL. OZ. JUICE / VINEGAR		
WEIGHT: 8.250 OZ 233.89 G		ITEM No. 11770		
PROJECT No. 19662 B/B		DATE 05/06/04	DRN. BY P. Steh	
REF: 3518 GLENSHAW		DWG. No.: B-94522		