

THIS DOCUMENT IS CONFIDENTIAL AND CONTAINS PROPRIETARY INFORMATION AND INTELLECTUAL PROPERTY INCLUDING, BUT NOT LIMITED TO, TRADEMARKS, COPYRIGHTS, TRADE SECRETS, AND KNOW-HOW OF ANCHOR GLASS. THIS INFORMATION MAY NOT BE USED, DISCLOSED OR REPRODUCED, IN WHOLE OR IN PART, WITHOUT THE PRIOR WRITTEN CONSENT OF ANCHOR GLASS. TITLE IN AND TO THIS DOCUMENT AND ALL INFORMATION CONTAINED HEREIN REMAINS AT ALL TIMES IN ANCHOR GLASS.

70-470 IT

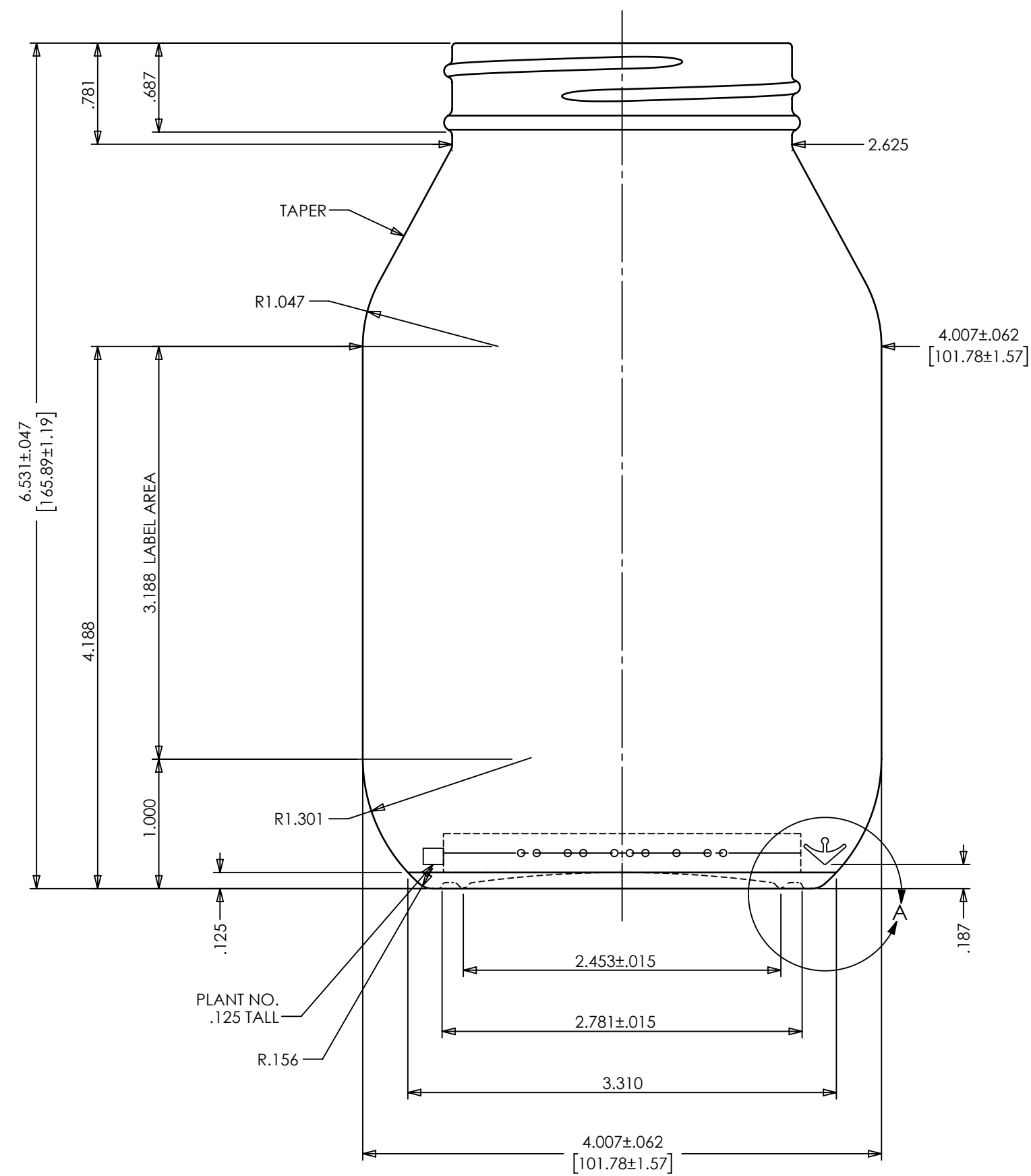

NOTE:
REGION BETWEEN 1.000 DIA. AND .400 DIA. IS FOR BINARY CAVITY NO. CODE ONLY AND MUST BE FREE OF ALL OTHER LETTERING.

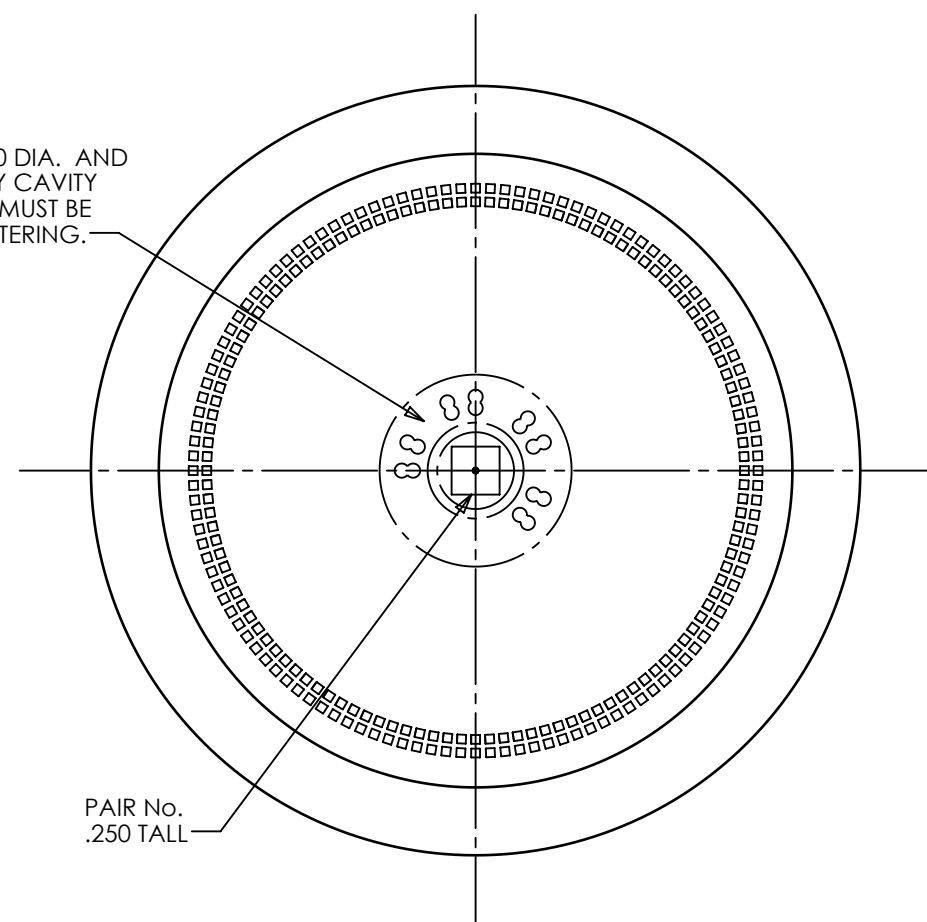

70-2030

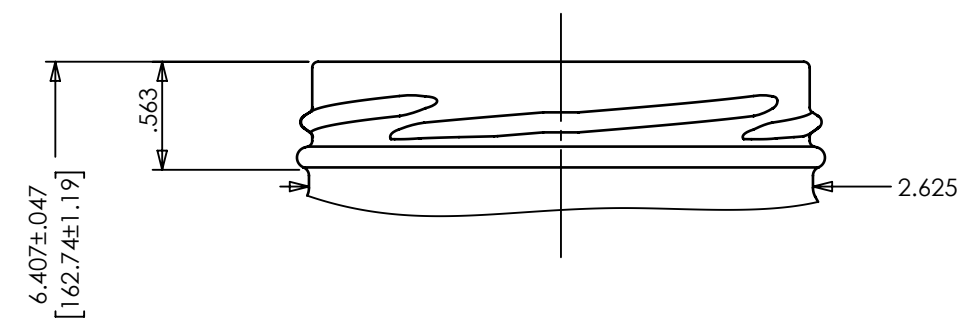

HEEL LETTERING: ROUND NOSE STYLE, RAISED .012"
KNURLING: BPK-170 KNURL TO APPEAR ON BEARING SURFACE
BOTTOM LETTERING: ROUND NOSE STYLE
TRADEMARK: No. 0

NOTE:
IF EMHART CAVITY IDENTIFICATION DOT CODE IS USED, THEY WILL APPEAR TWICE, CENTERED ONCE IN EACH HALF AS SHOWN. USE 10 DOT CODE ONLY.

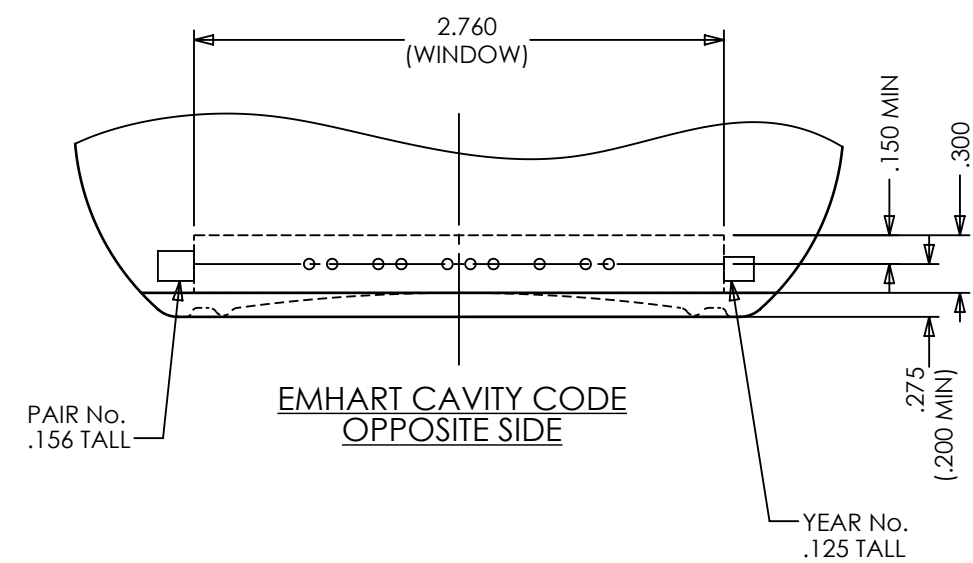

FINISH	OVERFLOW	WEIGHT
70-470 IT	33.100 ±.250 FL OZ	13.625 OZ
70-2030	32.800 ±.250 FL OZ	13.470 OZ

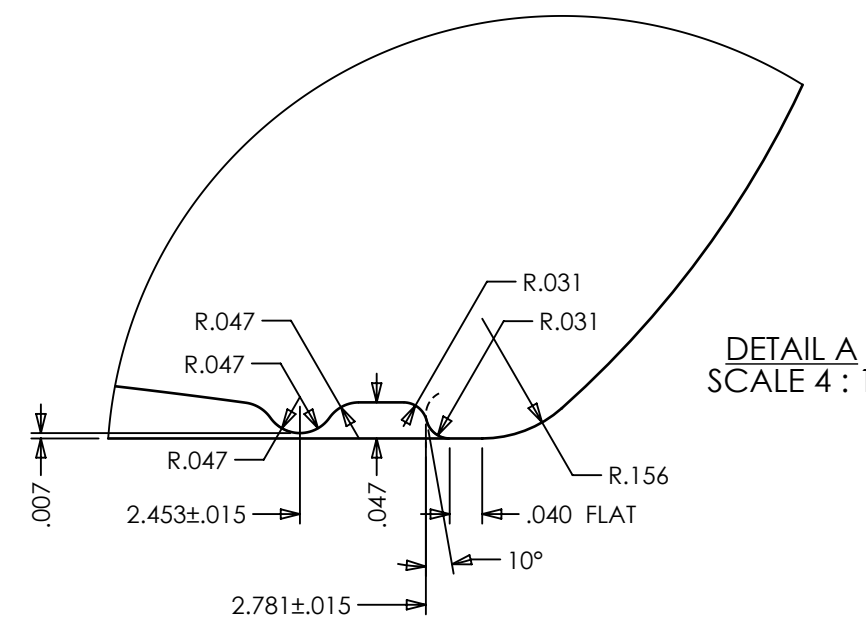

NOTES:
OVERALL HEIGHT: 6.531" (165.89mm)
LARGEST DIAMETER: 4.007" (101.78mm)
THEORETICAL TIP ANGLE > 26° 41'
THEORETICAL C.O.G: 2.762" UP FROM BASE OF BOTTLE

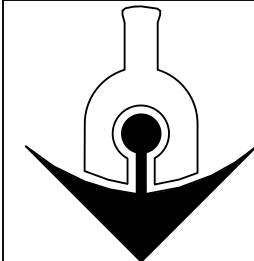

ANCHOR GLASS CONTAINER

TAMPA, FLORIDA

DESIGN/ENGINEERING		DESCRIPTION:	
SIZES & SPECIFICATIONS SHOWN ARE IDEAL ACTUAL SAMPLES WILL DETERMINE SIZES		GENERAL SALE	
SCALE: 1:1	SHAPE CODE: 10	32 OZ JAR	
OVERFLOW: SEE CHART		ITEM No.: 23307C	
NOMINAL CAPACITY: SEE CHART		DATE: 6/22/92	
WEIGHT: SEE CHART		DRN BY: D. Strohm	
PROJECT No: 19083		DWG No: B-88199	
REFERENCES: C-88199r4			

REV	DESCRIPTION	DATE	APPROVED
5	DRAWING NUMBER WAS C-88199 & ADDED 70-2030 FINISH	3/22/17	DT
4	UPDATED TO ANCHOR STANDARDS	9/15/15	DT
3	ADDED AGR PEANUTS & UPDATED DRAWING	7/23/04	CNM
2	LARGEST DIAMETER WAS 3.995. WEIGHT WAS 13.375 PER GLASS SAMPLES	5/12/03	CNM
1	UPDATED FORMAT & CHANGED CAPACITY FROM 32.800 FL OZ	1/25/01	CNM
REVISIONS			