

NOTE:
IF EMHART CAVITY IDENTIFICATION DOT CODE IS USED, THEY WILL APPEAR TWICE, CENTERED ONCE IN EACH HALF AS SHOWN. USE 10 DOT CODE ONLY.

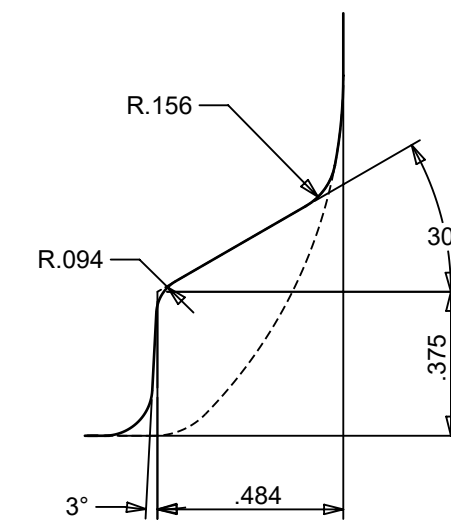
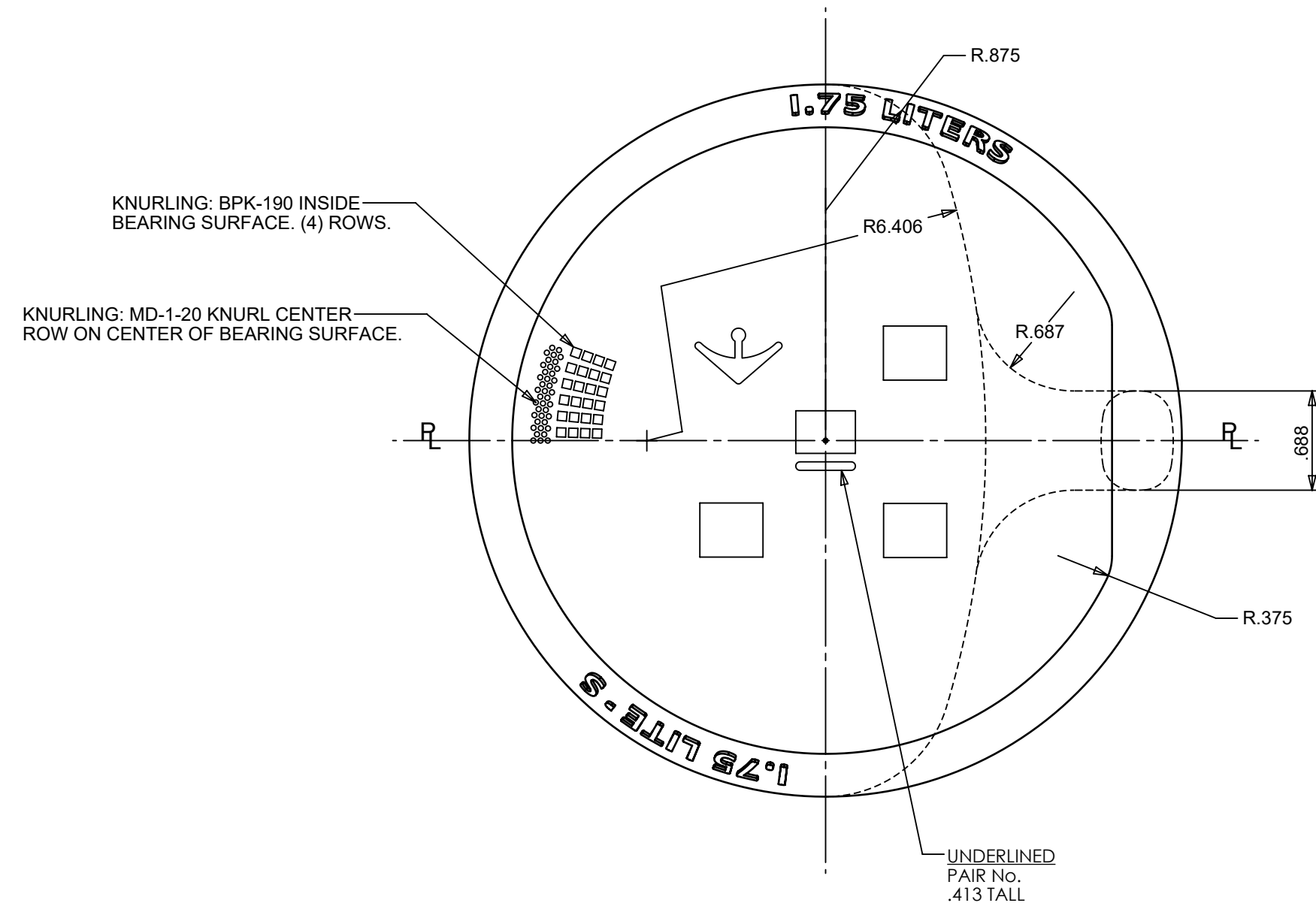
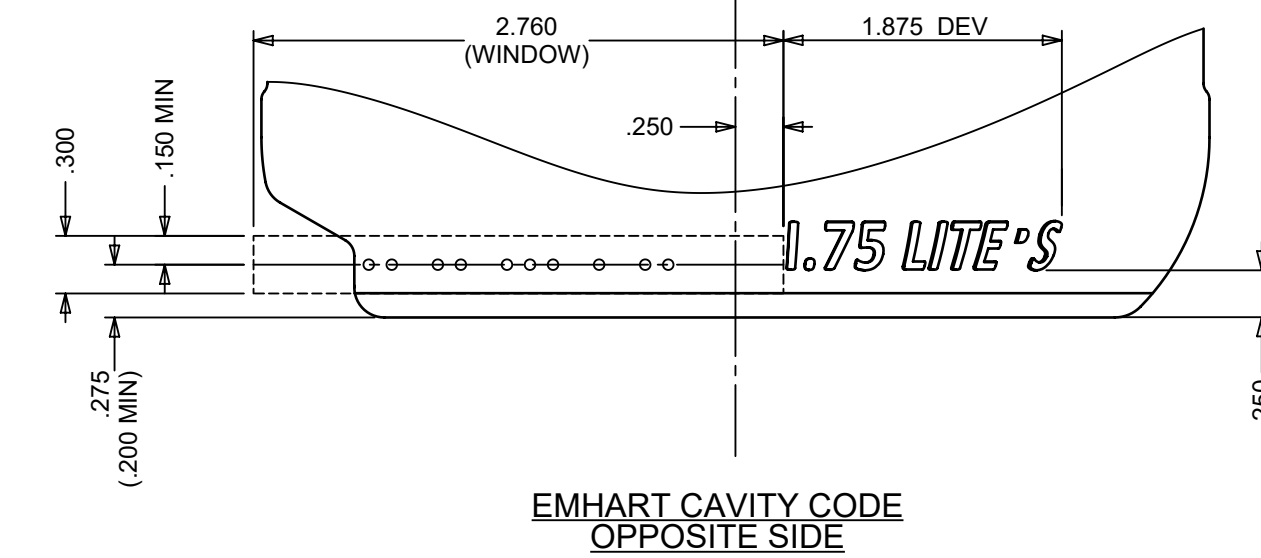
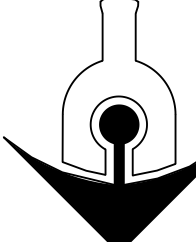

CAPACITY LETTERING: TO APPEAR ON EACH SIDE, ROUND NOSE STYLE, .250 TALL, RAISED .015 IN GLASS
BOTTOM PAIR No.: SEE DRAWING C-97764 FOR DETAILS
BOTTOM LETTERING: ROUND NOSE STYLE, USE LAYOUT #5

NOTES:
OVERALL HEIGHT: 12.029" (305.54mm)
LARGEST DIAMETER: 4.938" (125.43mm)
THEORETICAL TIP ANGLE > 24° 11'
THEORETICAL C.O.G: 4.398" UP FROM BASE OF BOTTLE

 ANCHOR GLASS CONTAINER		TAMPA, FLORIDA
DESIGN ENGINEERING SIZES & SPECIFICATIONS SHOWN ARE IDEAL ACTUAL SAMPLES WILL DETERMINE SIZES		DESCRIPTION:
SCALE: 1:1	SHAPE CODE: 18	GENERAL SALE
OVERFLOW: APPROX 60.700± .625 FL OZS 1795.11± 18.48 MLS		1.75 LITER HANDLE LIQUOR
NOMINAL CAPACITY: 59.180± .625 FL OZS 1750.00± 18.48 MLS		ITEM No.: 95927B
WEIGHT: 36.000± 1.500 OZS 1020.58± 42.52 GRAMS		DATE: 7/7/21 DRN BY: S. Thomas
1	REMOVED TENTATIVE NOTE & ADDED ITEM NUMBER	3/25/22 SAT
REV	DESCRIPTION	DATE APPROVED
REFERENCES: 19184		STATUS: BB
95927A		A-98173